

--	--	--	--	--	--	--	--	--	--

## Second Semester B.Arch. Degree Examination, Jan./Feb. 2023

### Building Structures – II

Time: 3 hrs.

Max. Marks: 100

*Note: Answer any FIVE full questions, choosing ONE full question from each module.*

#### Module-1

- 1 a. Define :
- |   |   |
|---|---|
| (i) Tensile stress and Compressive stress.    | (ii) Hooke's law.                         |
| (iii) Longitudinal strain and Lateral strain. | (iv) Poisson's ratio and Factor of safety |
- (08 Marks)
- b. A bar shown in Fig. Q1 (b) is subjected to a tensile load of 500 KN.  $E = 2 \times 10^5$  MPa.
- |                                       |                                 |
|---------------------------------------|---------------------------------|
| (i) Determine stress in each segment. | (ii) Maximum stress in the bar. |
| (iii) Total elongation of the bar.    |                                 |

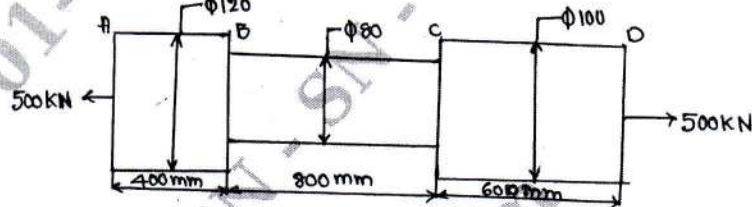

Fig. Q1 (b)

(06 Marks)

- c. A brass bar, having cross sectional area of  $1000 \text{ mm}^2$ , is subjected to axial forces as shown in Fig. Q1 (c). Find the total elongation of the bar. Take  $E = 1.05 \times 10^5 \text{ N/mm}^2$ .

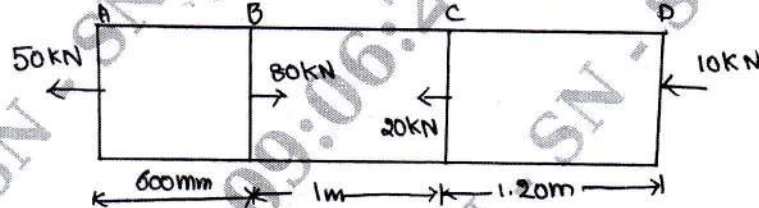

Fig. Q1 (c)

(06 Marks)

OR

- 2 a. Draw and explain stress-strain diagram of a mild steel specimen subjected to tension test. (06 Marks)
- b. A bar of 2 cm diameter is subjected to a pull 50 KN. The measured extension on gauge length of 250 mm is 0.12 mm and change in diameter is 0.00375 mm. Determine (i) Young's modulus (ii) Poisson's ratio (iii) Bulk modulus (iv) Modulus of rigidity. (07 Marks)
- c. A load of 2 MN is applied on a short concrete column  $500\text{mm} \times 500\text{mm}$ . The column is reinforced with four steel bar of 10 mm diameter, one in each corner. Find the stress in the concrete and steel bars. Take  $E$  for steel as  $2.1 \times 10^5 \text{ N/mm}^2$  and for concrete as  $1.4 \times 10^4 \text{ N/mm}^2$ . (07 Marks)

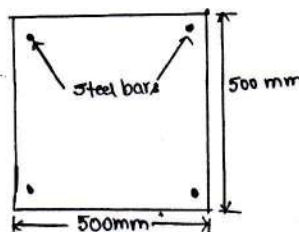

Fig. Q2 (c)

**Module-2**

- 3 a. Define : (i) Shear force (ii) Bending moment (iii) Shear force diagram  
 (iv) Bending movement diagram (v) Point of contraflexure (05 Marks)  
 b. Write a note on sign convention in S.F.D and B.M.D. (05 Marks)  
 c. A Cantilever of length 5.0 m is loaded as shown in Fig. Q3 (c). Draw S.F and B.M diagram for the cantilever.

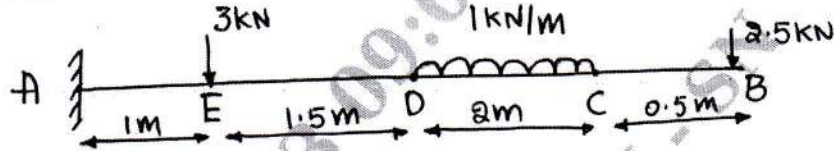

Fig. Q3 (c)

(10 Marks)

**OR**

- 4 a. A simply supported beam of length 10 m, carries the uniformly distributed load and two point loads as shown in Fig. Q4 (a). Draw the S.F and B.M diagram for the beam. Also calculate the maximum bending moment.

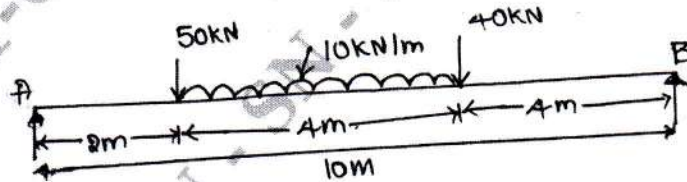

Fig. Q4 (a)

(10 Marks)

- b. Draw S.F and B.M diagrams for the over hanging beam carrying uniformly distributed load of 2 kN/m over the entire length and a point load of 2 kN as shown in Fig. Q4 (b). Locate the point of contraflexure.

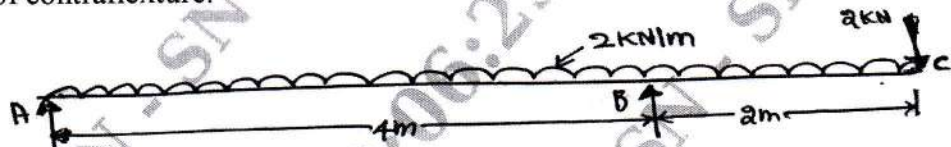

Fig. Q4 (b)

(10 Marks)

**Module-3**

- 5 a. Define : (i) Section modulus (ii) Pure bending (iii) Neutral axis (06 Marks)  
 b. What are the assumptions made in simple theory of bending? (04 Marks)  
 c. A rolled steel joist of I section has the dimensions as shown in Fig. Q5 (c). This beam of I section carries a u.d.l of 40 N/mm run on a span of 10 m. Calculate the maximum stress produced due to bending.

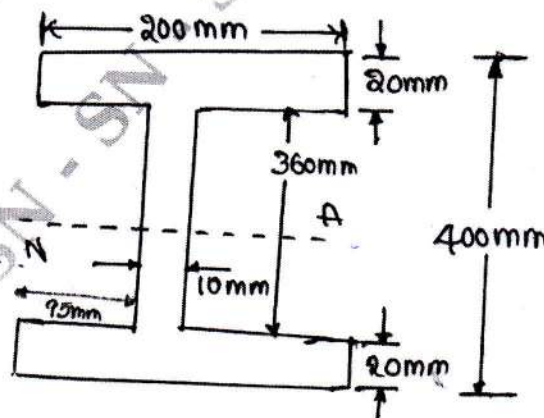

Fig. Q5 (c)

2 of 4

(10 Marks)



OR

- 6 a. Write the shear stress equation for beam and expand each of the notations in the equation. (04 Marks)
- b. A rectangular beam 100 mm wide and 250 mm deep is subjected to a maximum shear force of 50 kN. Determine
- Average shear stress
  - Maximum shear stress and
  - Shear stress at a distance of 25 mm above the neutral axis. (06 Marks)
- c. The shear Force acting on a section of a beam is 50 kN. The section of the beam is of T-shaped of dimensions 100mm × 100mm × 20mm as shown in Fig. Q6 (c). The moment of inertia about the horizontal axis is  $314.221 \times 10^4 \text{ mm}^4$ . Calculate the shear stress at the neutral axis and at the junction of the web and the flange.

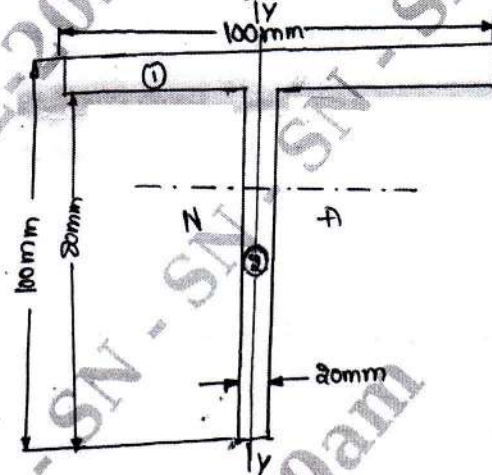

Fig. Q6 (c)

(10 Marks)

**Module-4**

- 7 a. Define :
- Column
  - Critical load.
  - Effective length of the column.
  - Slenderness ratio (08 Marks)
- b. Write the Elure's formula and expand the each of the notations in the equation. (04 Marks)
- c. A solid round bar 3 m long and 5 cm in diameter is used as a column determine the critical load using Euler's formula for the following conditions:
- Both the ends of column are fixed.
  - One end of the column is fixed and the other end free.
  - Both the ends of the column are hinged.
- Take  $E = 2.0 \times 10^5 \text{ N/mm}^2$  (08 Marks)

OR

- 8 a. What are the assumptions made in Euler's theory? (05 Marks)
- b. What is the "limitations of Euler's theory"? (05 Marks)
- c. An aluminium pipe column of length 3 m has inside and outside diameter of 125 mm and 150 mm respectively. Determine the critical loads for the following conditions :
- Both ends hinged
  - One end fixed one end free.
  - Both ends fixed.
  - One end fixed, one end hinged  $E = 7 \times 10^4 \text{ N/mm}^2$  (10 Marks)

**Module-5**

- 9 a. Write the assumption made in the moment curvature equation. (04 Marks)  
 b. Using double integration method, determine the slope and deflection for a simply supported beam subjected to UDL. (10 Marks)  
 c. A Cantilever of length 3 m is carrying a point load of 25 KN at the free end. If the moment of inertia of the beam =  $10^8 \text{ mm}^4$  and value of  $E = 2.1 \times 10^5 \text{ N/mm}^2$ . Find (i) Slope of the Cantilever at the Free end and (ii) Deflection at the Free end. (06 Marks)
- OR**
- 10 a. Define : Slope and deflection. (02 Marks)  
 b. Derive an expression for maximum slope and deflection for a Cantilever beam subjected to a concentrated load at the free end. (10 Marks)  
 c. A beam 6 m long simply supported at its ends, is carrying a point load of 50 KN at its centre. The moment of inertia of the beam is given as equal to  $78 \times 10^6 \text{ mm}^4$ . If E for the material of the beam =  $2.1 \times 10^5 \text{ N/mm}^2$ , calculate  
 (i) Deflection at the centre of the beam and  
 (ii) Slope at the supports. (08 Marks)

\*\*\*\*\*